

SINGLE NOZZLE COIL MARKER

The continuous writing coil marker (applicable for hot as well as cold coil purposes) has been designed around a standard robot for extreme mechanical reliability and high speed marking. Robots are in operation at numerous steel plants for many years and have proven to be reliable in tough conditions.

The robot, in combination with a special paint spray nozzle and heat resistant shielding, use non toxic, anti-clogging paint to provide a reliable mark for hot and cold coils. The coil marker measures the size of the coil and writes the characters in a bow or straight line at the flat face and (if required) in one or more lines at the circumference of the coil.



Features

- Full automatic marking
- No intermediate cleaning by blowing solvent in the open air between each marking cycle
- Flexible operation by using a standard robot
- Free programmable
- Non toxic, non-clogging paint
- Paint level indication and warning
- Easy installation integration in existing and new production lines
- Low maintenance costs

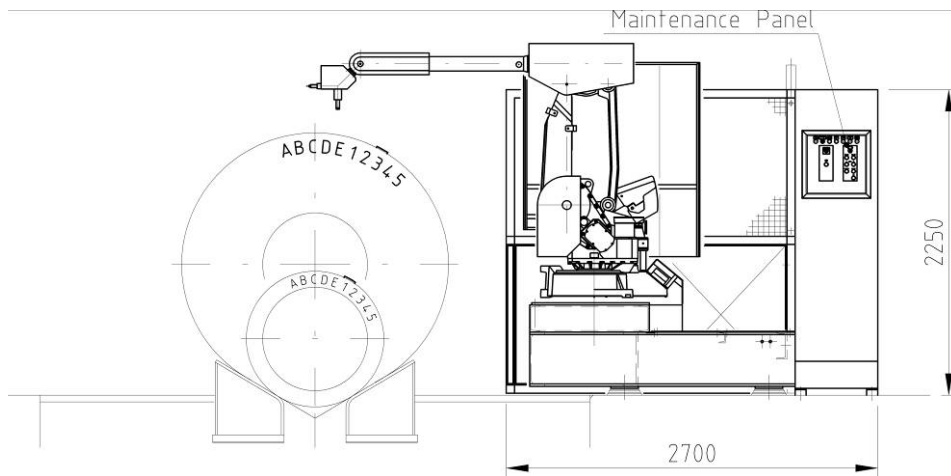

Standard Specification Hot Coil Marker

- Measuring time	16 sec
- Character writing time	1.0 sec per character
- Coil diameter	up to 2,700 mm
- Coil width	up to 2,200 mm
- Total weight marker	kg 2,700
- Control	Robot control + S7 3xx PLC
- Communication	Ethernet/Profibus DP
- Communication protocol	Any standard
- Max. coil surface temperature	750°C
- Paint colour	White
- Character height	mm 50 to 120 depending on coil size
- Overall height	2,250 mm
- Overall length	3,200 mm
- Overall depth	2,700 mm
- Power consumption	7,0 kW
- Supply voltage	any standard

Additional Options

- 7 x 5 Dot matrix marker (7 nozzles)
- Coil position with:
 - o eye to the sky
 - o perpendicular to the transport direction
- Heat Proof Label attachment
- PC in the operator pulpit
- Cold coil application
- Other paint colours on request

